

USBF President
Bill Pollack

USBF Vice President
Steve Beatty

USBF Secretary
Joan Gerard

USBF Treasurer
Sylvia Moss

USBF Chief Operations Officer
Jan Martel

USBF Chief Financial Officer
Barbara Nudelman

Director - USSBC
Terry Lavender

Appeals Coordinator

Joan Gerard
Co-Chairmen
Ron Gerard
Jeffrey Polisner
Committee:
Henry Bethe
Chip Martel
Robb Gordon
Howard Weinstein
Adam Wildawsky

VuGraph Organizer
Jan Martel

Bulletin Editor
Suzi Subeck

Hospitality Chair
Nadine Wood

Webmaster
Kitty Cooper

From the President



Welcome to the 2009 United States Bridge Federation Senior Trials.

We have eight teams in the USSBC vying for two slots in the Senior Bowl in Sao Paulo, Brazil, August 29th to September 12th. Good luck to all. We're glad you're here.

Sadly, Gene Freed is hospitalized and unable to play in the USSBC so his team was a late dropout. We were lucky, however, to get a fill-in team of expert locals. We appreciate that the members of the Epstein team changed their busy schedules to accommodate us. It would be great to see them in the finals!

Thanks to Jan Martel and the members of the USBC Tournament Committee for the extra time and effort they put into dealing with a difficult situation.

And, Gene, we wish you a speedy recovery.

Summerlin is an excellent venue for the Trials. There is much to do even when you are away from the bridge table. There are championship golf courses as well as the obvious casino entertainment ... for those who just can't get enough card play.

Above all, have fun, be courteous to one another ... and let's make this the best ever USSBC!!

From the Editor

Once again, the bulletins are being produced from a remote location. And once again, I ask your indulgence in being patient with the process.

These Trials are being held at the same time as Chicago's SummerFest Regional. I am onsite in St. Charles, IL doing the Bulletins for both events while playing the Knockout du Jour. *(apologies to my teammates)*

If you have any interesting hands, please contact me by phone at 708-927-6819 or by email me at stansubeck@prodigy.net. I will have easy access to both. Thanks and good luck!

Suzi



Teams Entered ... In Seeding Order ...

Larsen	Kyle Larsen, Capt Alan Sontag Bart Bramley	Rose Meltzer Roger Bates Lew Stansby
Lynch	Carolyn Lynch, Capt Mark Lair John Sutherlin	Mike Passell David Berkowitz Dan Gerstman
Schwartz	Richard Schwartz Russell Ekeblad Allan Cokin, NPC	Bob Jones Matthew Granovetter
Wolff	Bobby Wolff, Capt John Solodar Fred Hamilton	Dan Morse Paul Swanson Arnold Fisher
Kasle	Gaylor Kasle, Capt Ron Smith Neil Chambers	John Onstott Drew Casen John Schermer
Wojewoda	Edward Wojewoda, Capt Jim Looby James Tritt	Farid Assemi Keith Garber Bob Etter
Vernay	Colby Vernay, Capt Larry Griffey	Barry Schaffer Spike Lay
Epstein	Mark Epstein, Capt Jan George	Roberta Epstein Bob LaFleur

Growing old is
mandatory...
Growing up is
optional!!

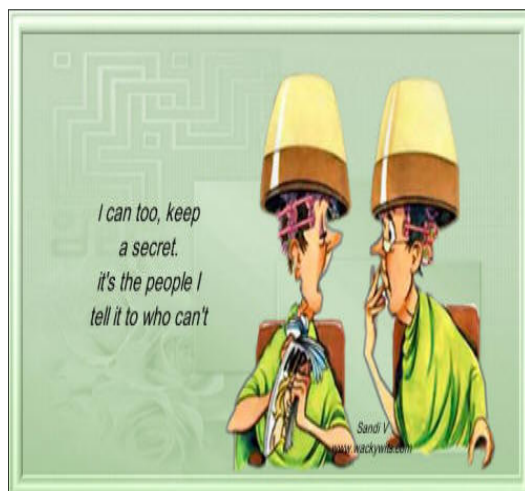

Alert Team Captains!!

There will be a Captain's meeting at 9:30 Monday morning in the playing room.

Please make certain your team is represented. There will be necessary information explained and disseminated.

Eating Out in and around Summerlin ...



When I was young I was called a rugged individualist. When I was in my 50s I was considered eccentric. Here I am doing and saying the same things I did then and I'm labeled senile.

-- George Burns

Terra Rossa, Italian, 11011 W. Charleston Blvd., (Red Rock Resort & Casino), 702-797-7576

Casual joint lures price-minded groups and pizza-loving guests for voluminous menu of Italian specialties including antipasto platters, seafood appetizers, pastas, and hearty meat or seafood entrees. Make sure to check out the kitchen staff, which includes Hell's Kitchen winner Heather West as a senior chef.

Agave, Mexican, 10820 W. Charleston Blvd., (S. Pavilion Center Dr.), 702-214-3500

Free of screaming slot-machines and all-day ambient lighting, this palatial Mexican joint dresses up the usual dishes with flavorful twists and market-fresh ingredients. The bar stocks 80 tequilas ranging from basic to exotic, with a staff knowledgeable enough to know the difference.

Bob Taylor's Original Ranch House, Steak, 6250 Rio Vista St., (Azure Dr.), 702-645-1399

This half-century-old steakhouse is way, way out of Vegas - almost to Mt. Charleston, actually. Located in a genuine ranch house decorated in way-back-vintage cowboy style, Bob Taylor's cooks up giant steaks on an open flame for hungry locals. If you're not up to eating like a starving ranch hand, you can always have an appetizer or two at the in-house sports bar.

Create, American, 7290 W. Lake Mead Blvd., (N. Tenaya Way), 702-586-0430

Create is the build-your-own-burger raised to the nth. Choose your size (mini, modest, majestic), patty

(beef, turkey, two vegetarian options), cheese (bleu, feta, pepperjack ,etc.), toppings (grilled onion, chopped egg, banana peppers, etc.), and sauce (Asian sesame, basil pesto, atomic mayo, etc.). Minimalist setting is brightened by pretty, friendly waitresses. And, of course, frozen custard, with daily-special flavors and over-the-top sundaes with goofy artist-pun names. Burger Bar and Luv-It, watch your backs.

Ferraro's, 5900 W. Flamingo Rd., (Jones Blvd.), 702-364-6300

Family-owned restaurant offers a classic Italian menu, from caprese di bufala to fettucini pomodoro to their signature osso buco. The conservative setting, with its faux-finish walls, dark wood, and framed prints of the old country draws a well-heeled crowd looking to wine and dine in discreet comfort.

Fleming's Prime, American, 8721 W. Charleston Blvd., (Town Center/Boca Park), 702-838-4774

Steak house/social scene creates an atmosphere with dark mahogany wood, tufted-leather upholstery, and sexy lounge furnishings. The beefy menu (with an occasional seafood twist) focuses on dry-aged meat specialties with gourmet dipping sauces and primal side dishes that feed fried cravings.

Gritz Cafe, Southern/Soul, 1911 Stella Lake St., (Mount Mariah Dr.), 702-255-4748

Small cafe with homestyle food and friendly service proves that, even in Vegas, you don't have to be flashy to succeed. The Gritz Cafe has built up a devoted following of locals who appreci-



ate their lovingly prepared takes on southern classics. All-day breakfast features already-legendary chicken and waffles, as well as state-themed plates like the Mississippi (eggs, grits, and catfish) or the Louisiana (eggs, grits, and hot links). Lunch offers catfish and shrimp po'boys, massive burgers, and baskets of chicken wings and fingers.

Hachi, Japanese, 11011 W. Charleston Blvd., (Red Rock Resort & Casino), 702-767-7656

Contemporary Japanese restaurant invites diners to mix and match with extensive menu of tempura, skewers, sashimi, hand rolls, and other small plates. Mod space is heavy on orange tones and cartoony shapes, but subdued lighting and downtempo music help chill out a crowd that's only starting their evening.

Hash House A Go-Go, American, 6800 W. Sahara Ave., (S. Rainbow Blvd.), 702-804-4646

They like their plates big in Las Vegas, but the portions at Hash House a Go-Go are downright daunting: Pancakes as big as 18-wheeler hubcaps, skateboard-sized slabs of meatloaf, bucketfuls of pot pie. Especially popular at breakfast, when a variety of diners fill the airy rustic-industrial space for family celebrations and post-hangover brunches.

LBS, American, 11011 W. Charleston Blvd., (Red Rock Resort and Casino), 702-835-9393

(Continued on page 4)

(Continued from page 3)

LBS—as in pounds—as in the vast selection of tricked-out half-pound burgers served here. The setting is described as "minimalist boudoir," with black leather banquettes behind black lace-printed glass, but the menu is all-American, offering twenty variations on the burger, including veggie and turkey. The house "perfect burger," may be just that: dry-aged beef topped with gruyere cheese, oven-roasted tomatoes, red onion marmalade, smoked bacon, and frisee.

Raku, Asian, 5030 Spring Mountain Rd., (S. Decatur Blvd.), 702-367-3511

Off-Strip Japanese spot draws in-the-know locals (including celeb chefs like seafood maven Rick Moonen) with a menu that extends far beyond sushi. The small, minimalist dining room puts diners in a peaceful frame of mind, the better to focus on grilled yakitori-style dishes like skewered tomatoes, Kobe beef with wasabi, and homemade tofu, as well as a range of noodle and soup bowls including salmon roe and foie gras.

Retro Bakery, Dessert, 7785 N. Durango Dr., (Brent Ln.), 702-586-3740

Kitschy, fifties-styled bakery specializes in cupcakes ranging from the chocolate and vanilla to the more, ahem, unusual. There's the milk and cookies--a chocolate-chip cake topped with frosting and a cookie--and the key lime pie and ice cream sundae varieties. But the piece de resistance is the maple bacon cupcake, a vanilla cupcake filled with bacon and maple syrup and topped with maple buttercream. It's only available on Fridays but, hey, if you're ever gonna have a bacon cupcake for breakfast at 7 am, now's the time.

Rosemary's, American (New), 8125 W. Sahara, (S. Buffalo Dr.), 702-869-2251

A favorite of local gourmets, Rosemary's is run by a pair of refugees from Emeril who do a sophisticated, Southern-tinged take on American cooking, turning out creative comfort food that draws local foodies and knowledgeable tourists. The extensive menu can be dizzying—each item has suggested beer and wine pairings—but be sure to try their specialty, Texas BBQ shrimp. Wednesdays are ladies' night, with 50% off on dinner for members of the fairer sex.

Salt Lick BBQ, American, 11011 W. Charleston Blvd., (Red Rock Resort & Casino), 702-797-7777

Sticky-finger oasis of thumb-licking BBQ lovers who often name this spot as one of Vegas' best Texas-style smokehouses--authentic right down to the imported Tito's vodka and Shiner beer. The dressy, stone-accented dining room features soaring ceilings, light-wood furnishings, and enough lone star state

Sedona, 9580 W Flamingo Rd., (Fort Apache Rd.), 702-320-5760

Gleaming, modernist building contains gleaming, modernist bar/restaurant best known for its busy young suburban singles scene. Yet another social spot backed by local tennis icon Andre Agassi, Sedona's soaring architectural patio, natural-stone interior, and starry lighting echo the nearby mountains. Kinda Asian, kinda Italian bistro food helps those on the prowl keep their strength up.

Shizen, Japanese, 221 N. Rampart Blvd., (JW Marriott), 702-869-7900

The bustling dining room has table seating and two open-air granite teppanyaki cook tops, where chefs combine cookery with entertainment and make meals to

order with flaming flair. The kitchen kicks out selections like chicken, Kobe beef, salmon, shrimp, and various vegetable side dishes.

Spiedini Ristorante, Italian, 221 N. Rampart Blvd., (JW Marriott), 702-869-6700

Famed chef and restaurateur Gustav Mauler combines a classic Milanese menu, fine wines, and architectural atmosphere. Dramatic woodwork and hand-blown Murano glass decorate the main dining room, though eyes are drawn to the open-kitchen area where diligent chefs cook up pastas, risottos, and grilled dishes. Candelit patio is a fine setting for romantic dinners.

T-Bones Chophouse, Steak, 11011 W. Charleston Blvd., (Red Rock Resort & Casino), 702-797-7576

The giant fire pit in the center of the dining room gives an idea of what's on at this meaty sanctuary: Dinosaur-sized chops and bicep-building steaks. Big-haired locals flaunting their well-worn Fendi baguettes trade up-and-down glances with a weekend LA crowd that had no idea how far away this over-styled restaurant was from the Strip.

T.C.'s Rib Crib, BBQ, 8740 W. Desert Inn Rd., (S. Durango Dr.), 702-451-7427

Featureless strip-mall eatery serves some of the best ribs in a barbecue-loving town. "Catfish Fridays," "lots o' meat" platters, and "down home desserts," as well as a half-dozen gooey sides named after members of the chef's family are heart-stopping and heart-stoppingly good.

To me, old age
is 15 years
older than I
am.

-- Bernard M.
Baruch



Vugraph

The 2009 USSBC will be covered on BBO Vugraph throughout. We hope to cover 2 matches each round. To watch the Vugraph online, go to the **BBO website** where you can either log on directly from your browser, go to "Vugraph" and choose which table to watch, or download the BBO software to run BBO on your computer. If you choose the latter approach, after downloading, install the software on your computer, log on, follow the directions to become a BBO member and you'll be magically transported to the Lobby of the largest bridge club in the world. Click on the button labeled EXPLORE BRIDGE and then on the button labeled VUGRAPH THEATRE and you'll be able to choose which of the USSBC matches you want to watch.

There may be a "yellow" user on BBO called USBF. If you have general questions, please ask USBF, not one of the hard-working Vugraph Operators, some of whom may prefer not to respond to private messages. If USBF is not online, it is because Jan is a Vugraph operator - she will be Vugraphu1 and will try to answer your general questions. Thank you.

Each day's schedule is the same (these are Las Vegas times; to see the times for your time-zone, go to the **BBO Vugraph schedule site**)

10:00-12:10
12:25-2:35
4:30-6:40
7:00-9:10

All of the teams in each bracket will play the same boards each segment. If a match is sufficiently far behind that another match starts early, the Vugraph presentation will not start until the slower match starts.

After a session, you can review the Vugraph action on our Web Vugraphs, which show each hand played with a link to bidding and play records. Take a look at the other 2009 events currently available to see what we'll have for the 2009 USSBC. Web Vugraphs are posted as soon as possible after completion of the Vugraph show.

HOSPITALITY SUITE INFORMATION

The hospitality suite for the 2009 USSBC is Room 6260 in the Palmer Tower of the JW Marriott Hotel. Players, kibitzers, friends and supporters are welcome in the Hospitality Suite during the tournament. Please join us for:

Breakfast each day from 8:30-10:00 am

Lunch each day from 2:30-4:30

Snacks, soft drinks, Vugraph and casual chat the rest of the day, except between 4:30 and 5:30 when the suite will be closed for cleaning



OLD IS WHEN

OLD IS WHEN...Your sweetie says, "Let's go upstairs and make love," and you answer, "Honey, I can't do both!"

OLD IS WHEN...Your friends compliment you on your new alligator shoes and you're barefoot.

OLD IS WHEN...A sexy babe catches your fancy and your pacemaker opens the garage door.

OLD IS WHEN...Going bra-less pulls all the wrinkles out of your face.

OLD IS WHEN...You don't care where your spouse goes, just as long as you don't have to go along.

OLD IS WHEN...You are cautioned to slow down by the doctor instead of the police.

OLD IS WHEN..."Getting a little action" means I don't need to take any fiber today.

OLD IS WHEN..."Getting lucky" means you find your car in the parking lot.

OLD IS WHEN...An "all nighter" means not getting up to pee!

MONDAY JULY 6	9:30 AM	CAPTAINS' MEETING (PLAYING ROOM)
Quarterfinals		
MONDAY JULY 6	10:00-12:10 12:25 - 2:30 2:30 - 4:30 4:30 - 6:40 7:00 - 9:10	SEGMENT 1 BOARDS 1-15 SEGMENT 2 BOARDS 16-30 2 HOUR BREAK SEGMENT 3 BOARDS 31-45 SEGMENT 4 BOARDS 46-60
Semi-Finals & USA2 Round of 16		
TUESDAY JULY 7	10:00-12:10 12:25 - 2:30 2:30 - 4:30 4:30 - 6:40 7:00 - 9:10	SEGMENT 1 BOARDS 1-15 SEGMENT 2 BOARDS 16-30 2 HOUR BREAK SEGMENT 3 BOARDS 31-45 SEGMENT 4 BOARDS 46-60
Final & USA2 Quarterfinals		
WEDS JULY 8	10:00-12:10 12:25 - 2:30 2:30 - 4:30 4:30 - 6:40 7:00 - 9:10	SEGMENT 1 BOARDS 1-15 SEGMENT 2 BOARDS 16-30 2 HOUR BREAK SEGMENT 3 BOARDS 31-45 SEGMENT 4 BOARDS 46-60
Final & USA2 Semi Finals		
THURS JULY 9	10:00-12:10 12:25 - 2:30 2:30 - 4:30 4:30 - 6:40 7:00 - 9:10	SEGMENT 5 BOARDS 61-75 SEGMENT 6 BOARDS 76-90 (Segments 1 & 2 of USA2 Semi-Finals) END OF USA1 USA2 SEMI-FINALS CONTINUE SEGMENT 3 BOARDS 31-45 SEGMENT 4 BOARDS 46-60
USA2 Final		
FRIDAY JULY 10	10:00-12:10 12:25 - 2:30 2:30 - 4:30 4:30 - 6:40 7:00 - 9:10	SEGMENT 1 BOARDS 1-15 SEGMENT 2 BOARDS 16-30 2 HOUR BREAK SEGMENT 3 BOARDS 31-45 SEGMENT 4 BOARDS 46-60

All About Kibitzing

WHEN CAN YOU KIBITZ IN THE PLAYING ROOMS?

You will be able to kibitz at any of the tables during this event. You will be subject to the following regulations:

Kibitzers may enter the room **ONLY** at the start of play for a segment. Once play has started, the room will be closed. A kibitzer who leaves the room may not return until the start of the next session.

Cell phones and other electronic devices are not allowed in the playing rooms, even if they are turned off. Any kibitzer who is found with a cell phone will be evicted and not allowed to kibitz during the remainder of the tournament.

When a match is being shown on BBO Vugraph, no kibitzer may sit on the same side of the table as the Vugraph operator.

SCREENS

All of the USSBC is played with screens. If you've never kibitzed at a table with screens before, you need to know that it is quite different from kibitzing at a regular table. You need to be seated at an "open" corner of the table (not next to the screen) in order to see much, and once there are 4 kibitzers at a table it will be very hard for additional kibitzers to see.

USBC KIBITZING RULES

The USBF **General Conditions of Contest** contain specific rules about kibitzers. They are designed to promote security at the tournament and are set forth in the conditions of contest section labeled "Security." They are:

1. General Rules

- a. During any use of duplicated boards across multiple matches, Kibitzers must select one table for kibitzing and may not move to any other table during a session or segment.
- b. Kibitzers may not speak with players, must watch only one hand at a time, may not sit in such a position as to see more than one hand at a time, may not sit in such a position as to see a computer screen in use for Internet broadcast, must check communication devices with the Director, cannot call attention to irregularities other than a board being placed incorrectly on the table (arrow positioning), but may serve as witnesses to a possible irregularity.

2. In the Open Room:

- a. If there is a live, or nearly live Internet broadcast of any match in the Open Room, kibitzers shall abide by the same rules as those applicable to the Closed Room.
- b. If there is no live, or nearly live Internet broadcast of any match in the Open Room then kibitzers, media, and NPC's may enter and return until such time as any table from the closed room has finished the segment. Once any table in the Closed room has finished, no one may return to the Open room after leaving unless escorted while absent.
- c. In either event, Open Room kibitzers are expected to abide by the same rules as the players regarding leaving the room and returning (e.g. be escorted to the restroom).

3. In the Closed Room:

- a. Kibitzers must enter the Closed Room before play commences. Kibitzers in the closed room are required to remain until the segment of play is completed at the table they are watching or to leave the playing area entirely. Closed Room kibitzers are expected to abide by the same rules as the players regarding leaving the room (e.g. be escorted to the restroom).
- b. Except as expressly provided in these conditions and appendices, NPC's shall be subject to the WBF General Conditions, Section 17.
- c. No one other than the Internet broadcast personnel and Tournament Directors may watch any computer screen or any other mechanism for enabling the Internet broadcast at any time in either the Closed or the Open Room.

**I refuse to admit that I am more than 52, even if
that does make my sons look illegitimate.
-- Nancy Astor**

Practicing for the Senior Trials... Winkle, Winkle, Little Star

Board 3 ♠ 76
 Dealer: S ♥ A8763
 E/W Vul. ♦ T9
 ♣ T752

♠ K2 ♠ AJ53
 ♥ QJ ♥ T952
 ♦ AKQJ63 ♦ 872
 ♣ AKQ ♣ J3

♠ QT984
 ♥ K4
 ♦ 54
 ♣ 9864



West	North	East	South
Lew Stansby	Hemant Lall	Bart Bramley	Nick Demirev
2♣	Pass	2♥	2♠
2NT	Pass	3NT	Pass
Pass	Pass		

Lew opened a strong, artificial and forcing 2♣. Bart showed two controls. Nick, being far too young for a Senior's event, stuck in a 2♠ call ... for the young at heart... not the faint of heart... Lew bid 2NT and Bart dutifully raised to game.

Hemant led the ♠7; Lew played small from dummy; Nick inserted the ten and Lew won his king.

Lew ran six rounds of diamonds and two rounds of clubs, coming to this four card end position:

Arthur is 90 years old. He's played golf every day since his retirement 25 years ago. One day he arrives home looking downcast.

"That's it," he tells his wife. "I'm giving up golf. My eyesight has gotten so bad that once I've hit the ball, I can't see where it went."

His wife sympathizes and makes him a cup of tea. As they sit down, she says, "Why don't you take my brother with you and give it one more try."

"That's no good," sighs Arthur. "Your brother's a hundred and three. He can't help."

"He may be a hundred and three," says the wife, "but his eyesight is perfect."

So the next day, Arthur heads off to the golf course with his brother-in-law. He tees up, takes an almighty swing, and squints down the fairway. He turns to the brother-in-law. "Did you see the ball?"

"Of course I did!" replies the brother-in-law. "I have perfect eyesight."

"Where did it go?" asks Arthur.

"I don't remember."

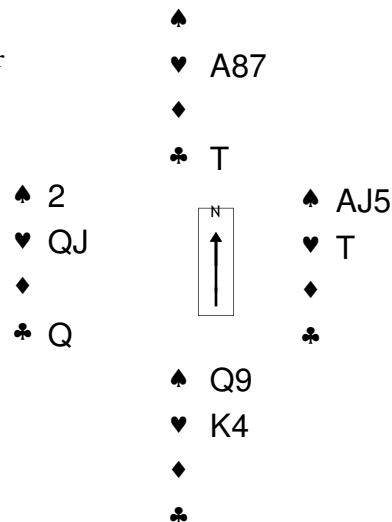

On the queen of clubs, Nick is squeezed.

He threw his ♥K.

Lew now played the ♥J. Hemant was forced to win and, holding only hearts, he exited the ♥7 to Lew's queen, and the ace of spades took the thirteenth trick. Making 6 was worth 6.9 IMPs.

Note: This will never happen in a Senior event since age teaches us not to overcall on such light hands!!

Note to Nick: Only kidding!!

(Continued on page 9)

(Continued from page 8)

Board 11 ♠ Q74
 Dealer: S ♥ 93
 None Vul. ♦ KQJ76
 ♣ AT2

♠ KT83 ♠ A95
 ♥ AK54 ♥ QJ762
 ♦ T43 ♦ 85
 ♣ J5 ♣ 864

♠ J62
 ♥ T8
 ♦ A92
 ♣ KQ973



West	North	East	South
Lew Stansby	Hemant Lall	Bart Bramley	Justin Lall
			1NT (10-12)
Pass	3NT	Pass	Pass
Pass			

Sometimes things work and sometimes they don't... and sometimes it pays to have only one play.

Look only at the East hand.

Partner leads the three of spades against 3NT. Too bad you're blessed with the nine! If you held Axx, you'd win the ace and return one... or win the ace and shift to a heart.

However, holding A95, you make the "correct" play of the nine and watch declarer scoop up one spade, five diamonds and five clubs! Who woulda thunk it?

West	North	East	South
Lew Stansby	Hemant Lall	Bart Bramley	Justin Lall
	1♥	3♠	Double
4♠	5♥	Pass	Pass
Double	Pass	Pass	Pass

Board 5 ♠ K32
 Dealer: N ♥ AKQ876
 N/S Vul. ♦ T864
 ♣

♠ A96 ♠ QJT874
 ♥ JT2 ♥ 94
 ♦ 95 ♦ 7
 ♣ AKQ73 ♣ 9854

♠ 5
 ♥ 53
 ♦ AKQJ32
 ♣ JT62



Give me distribution any time!

Can you blame Lew for doubling with his ♠A and ♣AKQ?

Maybe! The auction screams of distribution. And yes, he thinks his side might be making four spades... and perhaps, the opponents are saving... though the colors aren't right. In the end, however, there is no defense against SIX hearts let alone five.

Bart led his singleton diamond. Hemant won in dummy, pulled trumps, and claimed six.

-1050 cost Stansby/Bramley 4.5 IMPs. It was better than if the opponents had bid and made slam, but worse than if they'd played unmolested in five hearts.



**No Electronic Devices Are permitted in the Playing Area.
 Violators will be penalized.
 (Senior exception: Pace Makers are allowed.)**

With age comes wisdom...

I was walking down fifth avenue today and I found a wallet, and I was gonna keep it, rather than return it, but I thought: well, if I lost a hundred and fifty dollars, how would I feel? And I realized I would want to be taught a lesson.

When I was a kid I used to pray every night for a new bicycle. Then I realized the Lord doesn't work that way so I stole one and asked Him to forgive me.

Retirement Planning Advice

If you had purchased \$1000.00 of Nortel stock one year ago, it would now be worth \$49.00. With Enron, you would have had \$16.50 left of the original \$1000.00. With WorldCom, you would have had less than \$5.00 left. If you had purchased \$1000 of Delta Air Lines stock you would have \$49.00 left. But, if you had purchased \$1,000.00 worth of beer one year ago, drank all the beer, then turned in the cans for the aluminum recycling REFUND, you would have had \$214.00. Based on the above, the best current investment advice is to drink heavily and recycle.

"As you grow old, you lose interest in sex, your friends drift away and your children often ignore you. There are other advantages of course, but these are the outstanding ones."

"If people concentrated on the really important things in life, there'd be a shortage of fishing poles."

Warning! - NEVER UNDER ANY CIRCUMSTANCES take a sleeping pill and a laxative on the same night.

"These days, I spend a lot of time thinking about the hereafter. I go somewhere to get something... then wonder what I'm here after."

The only two things we do with greater frequency when we get older is urinate and attend funerals.

Do you realize that in about 40 years, we'll have thousands of old ladies running around with tattoos?

The Golden years are here at last.
I cannot see, I cannot pee.
I cannot chew, I cannot screw.
My memory shrinks, my hearing stinks.
No sense of smell, I look like hell.
The Golden years have come at last.
The Golden years can kiss my ass.

Why do they give you a watch when you retire when it's the first time in your life you don't care what time it is?

"I was thinking about how people seem to read the Bible a whole lot more as they get older. Then it dawned on me . . . they're cramming for their final exam."

"I've seen it all, done it all, heard it all. I just can't remember it all!"

Employment applications always ask who to notify in case of an emergency. I think you should write 'A Good Doctor' or '911'

Old age comes at a bad time.

Here are some good things that happen as you grow older:

Your investment in health insurance is finally beginning to pay off!

Kidnappers are not very interested in you.

It's harder and harder for sexual harassment charges to stick.

If you've never smoked, you can start now and it won't have time to hurt you.

Your secrets are safe with your friends because they can't remember them, either!!

Your eyes won't get much worse.

Things you buy now don't have time to wear out.

P	H		B			J	F			L			K	A	I	Y				X	G		
Q			D	X	L	A	E	M	C	N								V			B	H	
S	U			E	W			K		F	T	D			V						P	Q	
R						S	G					P	J	B			T	C	O	K			
							I	R	H	V	Y				K	W			A	T			
	O	S	L			R			Y	B	J	M			A	G		K		H	T		
			C			X	L	U	D			A	V	W	Q	M	O	Y		J			
H			U	M	K		W		S			Q	G	E	B		J	O		R	N	C	
				A	F						I	W	T		R	P	N	S		V		M	
Q	W	R			M	E		V	G			N		U	C	D	I						
			D	X							Q			R	P	O				B		V	
			G	C		Q	D				E	X	H		V	J	M	N	K	W		U	
		V					I		U	L			C	H		R					D		
W			O	J	V	M	E	B			I	U	T				L	F		A	S		
P	A						S	H	J			V								G	Q		
						V	O	Y	L		B				N	D	K	X			A	M	I
B			L			G	K	X	Q		V		M	T				P	N				
O	F	P			H	U			A	E	W	N			R	B		I	Y	L		X	
X	E		R	J		M		I	U	K				T	A	V	Y			D			
T	N		M		D	P				X	O	J	E		L		H	G		W			
		Q	F			G	N			M		B	P	C	Y								
		C	V	T	O			D	W	R				N		B						A	
Y	R				A			Q			V	U	O	E			D	B			N	S	
M	D			H								E	N	I	W	G	Q	A	L			C	
N	E					V	J	B	K			D			F	U			W	H	Y		

Giant Sudoku

My parents didn't want to move to Florida, but they turned 60 and that's the law. -- Jerry Seinfeld

Age is a question of mind over matter. If you don't mind, it doesn't matter. -- Satchel Paige

All would live long, but none would be old. -- Benjamin Franklin

Senior Quotes

Age is a high price to pay for maturity. -- Tom Stoppard

Each has his past to shut in him like the leaves of a book known to him by heart and his friends can only read the title. -- Virginia Woolf

Beautiful young people are accidents of nature, but beautiful old people are works of art. -- Eleanor Roosevelt

The secret of staying young is to live honestly, eat slowly, and lie about your age. -- Lucille Ball

Answers to puzzle... no peeking!!

1	6	8	5	F	B	A	4	0	E	7	C	9	2	3	D							
9	C	B	F	E	1	D	7	5	3	2	6	8	A	0	4							
4	7	0	D	3	2	6	C	9	8	B	A	F	E	1	5							
A	E	3	2	8	9	0	5	1	4	D	F	C	6	7	B							
C	1	D	7	B	3	F	8	2	A	0	4	E	9	5	6							
F	8	4	E	D	5	C	2	6	9	1	7	0	B	A	3							
2	5	6	3	9	A	7	0	B	D	E	8	4	1	F	C							
B	9	A	0	4	E	1	6	F	C	3	5	2	7	D	8							
8	4	7	C	A	F	B	E	D	0	6	2	5	3	9	1							
6	3	E	B	0	C	2	D	A	1	5	9	7	4	8	F							
0	F	2	A	1	8	5	9	C	7	4	3	6	D	B	E							
5	D	1	9	6	7	4	3	E	F	8	B	A	C	2	0							
D	A	5	4	2	0	8	1	3	6	9	E	B	F	C	7							
7	B	C	1	5	4	E	F	8	2	A	D	3	0	6	9							
E	2	9	6	C	D	3	B	7	5	F	0	1	8	4	A							
3	0	F	8	7	6	9	A	4	B	C	1	D	5	E	2							

Getting a Perfect Count ...

Board 17 ♠ J9
 Dealer: N ♥ AKx
 None Vul. ♦ AKQTx
 ♣ Axx

♠ QTxxx
 ♥ xxxx
 ♦ Jxxx
 ♣



♠ x
 ♥ xxx
 ♦ xxx
 ♣ KJTxxx

♠ AK8xx
 ♥ QJx
 ♦ 9
 ♣ Qxxx

This hand was played in the second round of the Friday-Saturday Knockouts at the recent Rockford, IL Regional tournament.

Both tables reached 6NT from North.

At one table, Jeff Miller, East, led his king of clubs ... looks grim, doesn't it?

At the other table, Mary Warden, East, led her ten of clubs... more promising?

The results may surprise you.

After the king of clubs lead, declarer had TWO chances to make the hand. He could play on spades and if that worked, he could bring in four spade tricks, three heart tricks, three diamond tricks and two club tricks for twelve. He led a spade toward the jack at trick two. Dick Bruno, West, won the queen and put declarer to the immediate guess by shifting to a diamond. If spades behaved,

declarer would not need the diamond suit. Accordingly, he rose with the ace. Even if spades did not break, the jack of diamonds might fall.

Unfortunately for him, neither suit worked and he failed by a trick.

After the ten of clubs lead, declarer played low and won the ace in hand while West pitched a heart. Declarer led a second club toward the queen, East winning her king and West pitching a second heart. East shifted to her singleton spade. North rose with the ace in dummy... no longer able to lose another trick and still make the hand.

After much thought, North went about getting a count... On three rounds of hearts, West parted with two hearts and two spades. He followed to the second high spade, East pitching a club. On the queen of clubs, West played another spade and declarer had a perfect count.

East had shown up with one only spade, three hearts, and six clubs... therefore, diamonds were breaking 4-3 with four in the West hand and three in the East hand. It doesn't seem like much of an edge, but it was the best she had. She took a first round finesse against the four card holding for the diamond jack.

Twelve tricks was worth 14 IMPs.

Men do not quit playing because they grow old; they grow old because they quit playing.
 -- Oliver Wendell Holmes

While there's snow on the roof, it doesn't mean the fire has gone out in the furnace.
 -- John G. Diefenbaker

Men become much more attractive when they start looking older. But it doesn't do much for women, though we do have an advantage: makeup.
 -- Bette Davis

And in the end, it's not the years in your life that count. It's the life in your years.
 -- Abraham Lincoln

You're only as young as the last time you changed your mind.
 -- Timothy Leary

I wasted time, and now doth time waste me.
 -- William Shakespeare

Senior Quotes

Morrie Makes His Move ...

Leave it to the Americans to hold their Senior Championships outside the betting capital of the world in the sizzling summertime. What appeals to Seniors more??? Cheap eats, half naked broads (hey, we can still look, can't we?), and plenty of laid-back action at the tables...

So you want to know my picks? Oy! Vey! It isn't easy ...

I really need more time to work through the numbers, but that Martel dame didn't make the matches till the eleventh hour ... C'mon Baby!! I can't wait all day. (Remember, I'm a Senior. I could DIE waiting for you to finish!! Or worse, I can forget who I picked before I write it down if you don't keep things moving... It's hard enough to keep things moving at my age... ANY things... Hey! Drink girlie... Me at the slot machines!! Bring me a prune juice!! Now!)

Anyway, back to the matters at hand, smart money says the broads will take the titles.

Expect to see Meltzer as USA1 and Lynch as USA2.

You can't judge a book by its cover. Those practice hands you read earlier in the Bulletin were just that: practice. Bart "Flannery" Bramley and Lew "almost took USA2 in the Open" will settle down and get serious ... They won't be playing the kids at these Trials and they won't have to deal with the Irish folks aka the "Shenanigans."

I'd take Sonty any day ... and Meltzer/Larsen are seasoned World Champs ... Throw in Bates and add to that the fact that Baze is looking down on his team and cheering ... it's a fait accompli!

FYI: I carded Carolyn to make sure she was old enough for this event... and it's legal... she can play. Rumor has it she's been all over the country practicing against live people... and her team's done just great.

They were spotted in Rockford at the Regional and won nearly everything and they were playing five handed... minus David. Factor Berkowitz "Son of Sam" into the equation and you got a "killer" team.

If you're looking for long shots, you oughta consider Wolff or Kasle. Wolff's fresh for the event... He's local now so he doesn't suffer jet lag. And his team stayed out of the Open ... and we oldsters wear out from too much of the game... (yawn!!)

Kasle's crew mostly avoided the Open and those who were in it didn't last long enough to wear themselves out.

Specific picks in tomorrow's edition...

Till then... no fighting at the table, guys... the fireworks were Saturday!

Goin' to the Craps table... Hey! Drink girl ... Bring me a double prune juice this time. Don't water it down and make it snappy... That should make me a winner at Craps one way or the other!

See you tomorrow!!

Morrie

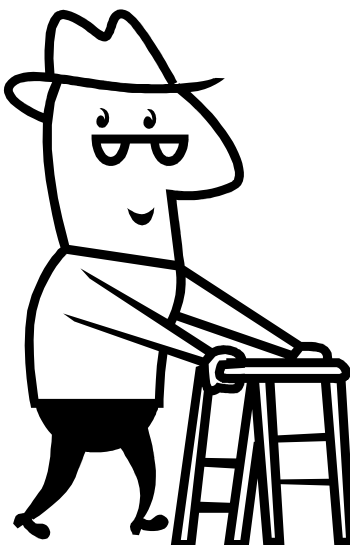

There's nothing worse than being an aging young person.
-- Richard Pryor

There is still no cure for the common birthday.
-- John Glenn

My doctor recently told me that jogging could add years to my life. I think he was right. I feel ten years older already.
-- Milton Berle

Time goes by. Reputation increases, ability declines.
-- Dag Hammarskjöld

First you forget names, then you forget faces. Next you forget to pull your zipper up and finally, you forget to pull it down.
-- George Burns

Old age is like everything else. To make a success of it, you've got to start young.
-- Fred Astaire

I think it would be interesting if old people got anti-Alzheimer's disease where they slowly began to recover other people's lost memories.
-- George Carlin

If wrinkles must be written upon our brows, let them not be written upon the heart. The spirit should never grow old.
-- John Kenneth Galbraith

I'll see a beautiful girl walking up to me and I'll think, Oh, my God, I can't believe my good luck. But then she'll say, "Where's your son?" or "My mother loves you."
-- James Caan

You know you're getting old when all the names in your black book have M.D. after them.
-- Arnold Palmer

It is not all bad, this getting old, ripening. After the fruit has got its growth it should juice up and mellow. God forbid I should live long enough to ferment and rot and fall to the ground in a squash.
-- Josh Billings

Cherish all your happy moments: they make a fine cushion for old age.
-- Christopher Marley

Forty is the age of youth; 50 is the youth of old age.
-- Victor Hugo

Beware of the young doctor and the old barber.
-- Benjamin Franklin

You can't reach old age by another man's road. My habits protect my life but they would assassinate you.
-- Mark Twain

More Senior Quotes

Seeding Information

The teams in the 2009 USSBC have been ranked by seeding points in accordance with the Conditions of Contest for the event.